

THERMALEC® ELECTRIC SWIMMING POOL HEATER 72PHR Series (48 kW to 72 kW)



Main Features

- The construction of the heater is solid and robust, to ensure years of safe and reliable service.
- The contact materials are highly resistant to corrosion from pool chemicals. Thermalec® pool and spa heaters can safely be used with sea water pools as well as in demanding applications such as Hydro- and Thalasso- therapy.
- The heating elements have a very low watts density, ensuring minimal scale build-up and long element life.
- The heating elements are always submerged in water. Any air bubbles entering the heater pass through it above the water and across the unheated parts of the elements, preventing any damage to the latter.
- The patented weir and baffle system inside the heater causes the water to flow through it in a spiral. This increases uniformity of the water temperature inside the heater and prevents direct impingement of cold water onto the elements.
- The spiral flow regime of the water inside the heater discourages scale formation, extending element life.
- The heaters have no flow switch. These are notoriously unreliable. Any air bubbles passing through the heater will cause any flow switch to make and break repeatedly in rapid succession, causing the contactors to do the same, thus shortening their life.
- Thermalec® heaters are flexible: The water flow direction is normally left to right. If required, this can be easily changed on installation by means of a simple modification.
- The thermostats used in Thermalec® pool and spa heaters have a low operating differential. This is essential to maintain the swimming pool at a virtually constant temperature. Heaters with higher operating differentials are likely to allow the pool to cool to an uncomfortably low temperature before switching the heating on.
- The 72PHR heaters are equipped with mains circuit breakers, a detail often overlooked in pool heaters.
- Top quality contactors have been used and their ratings generously selected to give a long service life and minimum risk of operational problems, particularly in pool plant room conditions.
- The heating elements on 72PHR models are organised in two banks. A time delay relay engages the contactors in two separate stages to reduce electrical surge and avoid a voltage drop when the heater switches on. The heaters are also equipped with a two stage temperature controller that overrides the time delay in the event of a rapid temperature rise.
- As a safety precaution, the heaters are provided with an interlock relay, which has to be connected to the filter pump control circuit. The heater will not operate unless the interlock is wired and the filter pump is energised.
- Status indicator lamps on front of panel to facilitate troubleshooting and diagnostics.
- Thermalec® pool and spa heaters comply with all current and relevant EU regulations and directives.
- Thermalec® pool and spa heaters have a two-year guarantee.

Thermalec® 72PHR Series electric pool heater

Description

Thermalec® electric heaters are specifically designed for use with swimming pools and spas. The base of the heater is a fusion epoxy coated cast iron vessel through which the water from the swimming pool flows. The vessel is fitted with two safety pressure relief valves, a drain valve and the water inlet and outlet nozzles and its base is designed to support the heater on a flat, solid surface. Four screws are supplied to enable the heater to be levelled.

Overflow weirs are cast into the inside of the heater vessel at the inlet and outlet nozzles. These ensure that the vessel is kept filled with water to a constant level at all times. A baffle plate is suspended inside the heater across its width, downstream of the inlet weir. A similar baffle plate is suspended upstream of the outlet weir. The top edges of each of the cast weirs are slightly sloped. This patented combination of weirs and baffles is designed to impart a spiral regime to the flow of water through the heater. It also prevents the direct impingement of cold water directly on to the heating elements.

The inlet and outlet pipework are connected to the heater by uPVC solvent weld socket stub flanges. These are attached to the inlet and outlet ports on the cast iron vessel by a steel backing flange, ensuring that the uPVC socket can be replaced if ever that were necessary.

The outer sheath metal of the spiral circular heating elements is in highly corrosion resistant Incoloy 825. The heating elements are suspended inside the vessel from the thick uPVC element holding plate that covers the top of the vessel and from which the removable baffles are also suspended. The heating elements are fitted with their smallest profiles facing the direction of flow. The terminal ends of each element pass through glands in the element holding plate and into the heater control enclosure that is fixed to the top of it. Two temperature pockets protrude into the vessel through the element holding plate, one at the inlet end and the other at the outlet end. These contain the probes of the control and safety over-temperature liquid-filled capillary type

Operation

Before switching any power on, it is ensured that the heater is full of water and that water is flowing through it. The mains power is then switched on, followed by the circuit breakers on the heater. A red indicator shows that the heater is powered. An amber light on the heater indicates that the filter pump is in operation. If the pump does not operate or if the pump interlock has not been fitted, the heater will not heat.

The desired pool temperature is now set using the thermostat dial. Two green lights on the heater light in sequence, with a short time delay in between, indicating that the two heating element

thermostats, respectively. An additional pocket accommodates the probe for the pool water temperature thermometer. The joint between the uPVC element holding plate and the top flange of the cast iron vessel is made tight by a temperature resistant silicone rubber gasket.

The powder coated steel heater control enclosure houses the electrical switchgear, the power connection terminals and control components.

Mains circuit breakers are provided. They will interrupt the mains power supply should any problems occur during the normal running of the heater. Power is supplied to the elements through heavy duty contactors. An interlock relay is provided to ensure that no mains power can be supplied to the heating elements if the interlock signal from the main pool filter pump is absent.

The heating elements on 72PHR models are organised in two banks. A time delay relay engages the contactors in two separate stages to reduce electrical surge and avoid a voltage drop when the heater switches on. The heaters are also equipped with a two stage temperature controller that overrides the time delay in the event of a rapid temperature rise.

The supply of power to the heating elements is also conditioned by the two-stage control thermostat and the over-temperature safety thermostat, which must both be set for power to be supplied to the elements. The over-temperature thermostat is provided with a circuit breaker shunt trip that is activated on attainment of the factory set temperature. This trip must be manually reset to permit power to be supplied to the elements. A fuse protects the heater power circuits, and a second fuse protects the heater status indicator lamps.

The front face of the enclosure forms the heater control panel and accommodates the mains circuit breakers, the pool temperature setting dial, heater status indicator lamps, the over-temperature thermostat manual reset button, and the indicator dial of the pool water temperature thermometer.

banks are powered and water is being heated. When the set temperature is reached, the green lights are extinguished. A white light on the heater indicates that the water temperature is below the factory set safety thermostat trip level. If this temperature is reached, the heater has overheated. In this case, the safety thermostat trips and the unit is shut down. This trip must be reset manually.

In normal operation, the green lights will only be lit (and heating will occur) if all the other lamps are lit and the pool water temperature is below the set temperature.

Thermalec® 72PHR Series electric pool heater

Standards

Thermalec® pool and Spa heaters are CE marked and comply with:

EU Council Directive 89/336/EEC & 93/068/EEC on Electromagnetic compatibility

EU Council Machinery Directive 98/37/EEC

EU Council Low Voltage Directive 2006/95/EEC & 72/23EEC

Harmonised Standards: EN55014, EN55104, EN5501, EN5502, CEI801-2, CEI801-3 and EN60335-2-35

Technical details

Materials of construction

Heater vessel:	Fusion epoxy coated cast iron	Element holding plate:	uPVC
Gasket:	Silicone rubber	Water connections:	uPVC socket
Heater elements:	Incoloy 825 sheath	Electrical enclosure:	Powder coated steel

Operating data

Water inlet/outlet	Socket for 50 mm or 2" NB pipe	Max. water temp.:	52°C heater outlet
Operating pressure:	2.0 barg max.	Ambient temp.:	40°C max.
Pool temp. Control range:	15°C to 45°C	Thermostat operating diff.:	0.5 C°

Water Flowrate ranges

	Installed heater power		
	48 kW	60 kW	72 kW
Maximum (hard water) l/min.	300	300	300
Maximum (soft water) l/min.	150	150	150
Minimum l/min.	73	91	109

Control and indication

Power supply isolation:	1 x 3-pole 100 Amp (48 & 60 kW heaters) or 2 x 3-pole 60 Amp (72 kW heaters) heavy duty circuit breakers on front fascia.
Water temperature cut-out:	Factory set to trip at water outlet temperature of 52°C. Manual reset on front fascia.
Thermostats:	Pressurised liquid filled capillary type.
Pool temperature indicator:	Pressurised liquid filled capillary thermometer with analogue indicator dial.
Pool temperature control:	Analogue dial, calibrated 15°C to 45°C and graduated at 1C° intervals.
Mains indicator lamps:	Red (mains power on), Amber (filter pump interlock power present)
Status indicator lamps:	Red (heater circuit breaker armed and powered) White (safety thermostat trip armed), Amber (pump interlock relay OK), 2 x Green (heating elements powered).

Electrical data

Protection level:	IP 21	Fuses:	2 x 2 Amp
Pump interlock voltage:	230 V AC	Element heat flux:	11.5 W/cm ² max.

Standard Power Supply: 400V/3ph/50Hz

Model Ref.	Load kW	Current Amps	Elements (no. x nominal kW)
72PHRX48	48	73	12 x 4 kW
72PHRX60	60	91	15 x 4 kW
72PHRX72	72	108	18 x 4 kW

Thermalec® 72PHR Series electric pool heater

Electrical data (cont'd.)

Power Supply: 380V/3ph/50Hz			
Model Ref.	Load kW	Current Amps	Elements (no. x nominal kW)
72PHRX48V	48	73	12 x 4 kW
72PHRX60V	60	91	15 x 4 kW
72PHRX72V	72	108	18 x 4 kW

Power Supply: 380V/3ph/50Hz			
Model Ref.	Load kW	Current Amps	Elements (no. x nominal kW)
72PHRX48DV	48	126	12 x 4 kW
72PHRX60DV	60	158	15 x 4 kW
72PHRX72DV	72	189	18 x 4 kW

Weights and dimensions

Packed dimensions:

660 x 450 x 470 mm

Packed weight:

81 kg

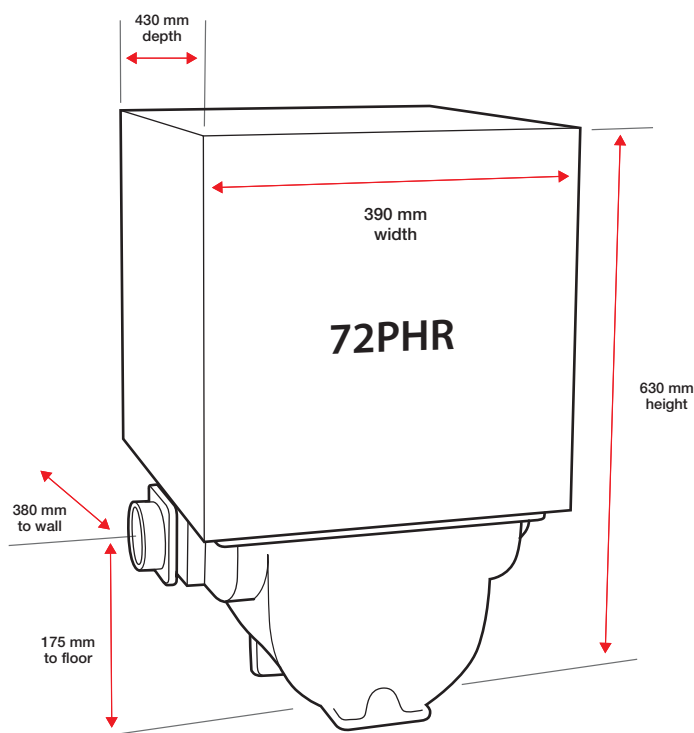

Thermalec Pool & Spa Products

Kingsley Close, East Way, Lee Mill Industrial Estate
Ivybridge, Devon PL21 9LL United Kingdom
Telephone +44 (0) 1752 313343
Fax +44 (0) 1752 313353
E-mail info@thermalec.co.uk
Web www.thermalec.co.uk

THERMALEC®
POOL & SPA PRODUCTS