

## THERMALEC® ELECTRIC SWIMMING POOL HEATER 12PHR Series (3 kW to 12 kW)



### Main Features

- The construction of the heater is solid and robust, to ensure years of safe and reliable service.
- The contact materials are highly resistant to corrosion from pool chemicals. Thermalec® pool and spa heaters can safely be used with sea water pools as well as in demanding applications such as Hydro- and Thalasso- therapy.
- The watts density of the heating elements is very low, ensuring minimal scale build-up and long element life.
- The heating elements are always submerged in water. Any air bubbles entering the heater pass through it above the water and across the unheated parts of the elements, preventing any damage to the latter.
- The patented weir and baffle system inside the heater causes the water to flow through it in a spiral. This increases uniformity of the water temperature inside the heater and prevents direct impingement of cold water onto the elements.
- The spiral flow regime of the water inside the heater discourages scale formation, extending element life.
- The heaters have no flow switch. These are notoriously unreliable. Any air bubbles passing through the heater will cause any flow switch to make and break repeatedly in rapid succession, causing the contactors to do the same, thus shortening their life.
- Thermalec® heaters are flexible: The water flow direction is normally left to right. If required, this can be easily changed on installation by means of a simple modification. Most models may be easily changed by a qualified electrician from single to three phase operation and vice-versa.
- The thermostats used in Thermalec® pool and spa heaters have a low operating differential. This is essential to maintain the swimming pool at a virtually constant temperature. Heaters with higher operating differentials are likely to allow the pool to cool to an uncomfortably low temperature before switching the heating on.
- Top quality contactors have been used and their ratings generously selected to give a long service life and minimum risk of operational problems, particularly in pool plant room conditions.
- As a safety precaution, the heaters are provided with an interlock relay, which has to be connected to the filter pump control circuit. The heater will not operate unless the interlock is wired and the filter pump is energised.
- Status indicator lamps on front of panel to facilitate troubleshooting and diagnostics.
- Thermalec® pool and spa heaters comply with all current and relevant EU regulations and directives.
- Thermalec® pool and spa heaters have a two-year guarantee.

# Thermalec® 12PHR Series electric pool heater

## Description

Thermalec® electric heaters are specifically designed for use with swimming pools and spas. The base of the heater is a fusion epoxy coated cast iron vessel through which the water from the swimming pool flows. The vessel is fitted with a safety pressure relief valve, a drain valve and the water inlet and outlet nozzles and its base is designed to support the heater on a flat, solid surface. Four screws are supplied to enable the heater to be levelled.

Overflow weirs are cast into the inside of the heater vessel at the inlet and outlet nozzles. These ensure that the vessel is kept filled with water to a constant level at all times. A baffle plate is suspended inside the heater across its width, downstream of the inlet weir. A similar baffle plate is suspended upstream of the outlet weir. The top edges of each of the cast weirs are slightly sloped. This patented combination of weirs and baffles is designed to impart a spiral regime to the flow of water through the heater. It also prevents the direct impingement of cold water directly on to the heating elements.

The inlet and outlet pipework are connected to the heater by uPVC solvent weld socket stub flanges. These are attached to the inlet and outlet ports on the cast iron vessel by a steel backing flange, ensuring that the uPVC socket can be replaced if ever that were necessary.

The outer sheath metal of the spiral circular heating elements is in highly corrosion resistant Incoloy 825. The heating elements are suspended inside the vessel from the thick uPVC element holding plate that covers the top of the vessel and from which the removable baffles are also suspended. The heating elements are fitted with their smallest profiles facing the direction of flow. The terminal ends of each element pass through glands in the element holding plate and into the heater control enclosure that is fixed to the top of it. Two temperature pockets protrude into

the vessel through the element holding plate, one at the inlet end and the other at the outlet end. These contain the probes of the control and safety over-temperature liquid-filled capillary type thermostats, respectively. The joint between the uPVC element holding plate and the top flange of the cast iron vessel is made tight by a temperature resistant silicone rubber gasket.

The powder coated steel heater control enclosure houses the electrical switchgear, the power connection terminals and control components. For spa applications, some models are fitted with oversized enclosures to assist heat dissipation from the electrical switchgear.

A mains ON/OFF switch is provided on the heater. Power is supplied to the elements through heavy duty contactors. An interlock relay is provided to ensure that no mains power can be supplied to the heating elements if the interlock signal from the main pool filter pump is absent.

The supply of power to the heating elements is also conditioned by the control thermostat and the over-temperature safety thermostat, which must both be set for power to be supplied to the elements. The over-temperature thermostat causes the contactor to trip on attainment of the factory set maximum water temperature. This trip must be manually reset to permit power to be supplied to the elements.

A fuse protects the heater control circuits and the heater status indicator lamps.

The front face of the enclosure forms the heater control panel and accommodates the mains on/off switch, the pool temperature setting dial, heater status indicator lamps and the over-temperature thermostat manual reset button.

## Operation

Before switching any power on, it is ensured that the heater is full of water and that water is flowing through it. The mains power is then switched on, followed by the on/off switch on the heater. A red indicator shows that the heater is powered. An amber light on the heater indicates that the filter pump is in operation. If the pump does not operate or if the pump interlock has not been fitted, the heater will not heat.

The desired pool temperature is now set using the thermostat dial. A green light on the heater indicates that the heating elements are powered and water is being heated. When the set

temperature is reached, the green light is extinguished. A white light on the heater indicates that the water temperature is below the factory set safety thermostat trip level. If this temperature is reached, the heater has overheated. In this case, the safety thermostat trips and the unit is shut down. This trip must be reset manually.

In normal operation, the green light will only be lit (and heating will occur) if all the other lamps are lit and the pool water temperature is below the set temperature.

# Thermalec® 12PHR Series electric pool heater

## Standards

Thermalec® pool and Spa heaters are CE marked and comply with:

EU Council Directive 89/336/EEC & 93/068/EEC on Electromagnetic compatibility

EU Council Machinery Directive 98/37/EEC

EU Council Low Voltage Directive 2006/95/EEC & 72/23EEC

Harmonised Standards: EN55014, EN55104, EN5501, EN5502, CEI801-2, CEI801-3 and EN60335-2-35

## Technical details

### Materials of construction

Heater vessel:	Fusion epoxy coated cast iron	Element holding plate:	uPVC
Gasket:	Silicone rubber	Water connections:	uPVC socket
Heater elements:	Incoloy 825 sheath	Electrical enclosure:	Powder coated steel

### Operating data

Water inlet/outlet	Socket for 40 mm or 1½" NB pipe	Max. water temp.:	52°C heater outlet
Operating pressure:	2.0 barg max.	Ambient temp.:	40°C max.
Pool temp. Control range:	15°C to 45°C	Thermostat operating diff.:	0.5 C°

### Water Flowrate ranges

	Installed heater power						
	3 kW	4 kW	6 kW	7.5 kW	9 kW	10 kW	12 kW
Maximum (hard water) l/min.	152	152	152	152	152	152	152
Maximum (soft water) l/min.	76	76	76	76	76	76	76
Minimum l/min.	4.5	6	9	11	14	15	18

### Control and indication

Power supply isolation:	ON/OFF switch on front fascia.
Water temperature cut-out:	Factory set to trip at water outlet temperature of 52°C. Manual reset on front fascia.
Thermostats:	Pressurised liquid filled capillary type.
Pool temperature control:	Analogue dial, calibrated 15°C to 45°C and graduated at 1C° intervals.
Mains indicator lamps:	<b>Red</b> (mains power on), <b>Amber</b> (filter pump interlock power present)
Status indicator lamps:	<b>Red</b> (heater ON/OFF switch ON), <b>White</b> (safety thermostat trip armed), <b>Amber</b> (pump interlock relay OK), <b>Green</b> (heating elements powered).

### Electrical data

Protection level:	IP 21	Fuses:	1 x 2 Amp (+1 spare)
Pump interlock voltage:	230 V AC	Element heat flux:	11.5 W/cm² max.

#### Standard Power Supply: 230V/1ph/50Hz or 400V/3ph/50Hz

Model Ref.	Load kW	Current Amps 1-ph/3-ph	Elements (no. x nominal kW)	1-phase version	3-phase version
12PHRX3	3	14/n.a.	1 x 3 kW	Yes	No
2PHRX4	4	17/n.a.	1 x 4 kW	Yes	No
12PHRX6	6	27/n.a.	2 x 3 kW	Yes	No
12PHRX7.5	7.5	33/11	3 x 2.5 kW	Yes	Yes
12PHRX9*	9	40/13	3 x 3 kW	Yes	Yes
12PHRX12*	12	53/17	3 x 4 kW	Yes	Yes

Models marked \* are not suitable for spa use. For 9 and 12 kW heaters, use models 12PHR9/SPA and 12PHR12/SPA respectively.

# Thermalec® 12PHR Series electric pool heater

## Electrical data (cont'd.)

Power Supply: 220V/1ph/50Hz or 380V/3ph/50Hz					
Model Ref.	Load kW	Current Amps 1-ph/3-ph	Elements	1-phase version	3-phase version
12PHRX4V	4	19/n.a.	1 x 4 kW	Yes	No
12PHRX6V	6.3	28/n.a.	2 x 3 kW	Yes	No
12PHRX7.5V	7.5	35/12	3 x 2.5 kW	Yes	Yes
12PHRX10V*	10	46/16	1 x 4 kW + 2 x 3 kW	Yes	Yes
12PHRX12V*	12	55/19	3 x 4 kW	Yes	Yes

Models marked \* are not suitable for spa use. For 10 and 12 kW heaters, use models 12PHR10V/SPA and 12PHR12V/SPA respectively.

Power Supply: 220V/2ph/60Hz or 220V/3ph/50Hz (Delta wiring)					
Model Ref.	Load kW	Current Amps 1-ph/3-ph	Elements	1-phase version	3-phase version
12PHRX4DV	4	19/n.a.	1 x 4 kW	Yes	No
12PHRX6DV	6.3	29/n.a.	2 x 3 kW	Yes	No
12PHRX7.5DV	7.5	n.a./20	3 x 2.5 kW	No	Yes
12PHRX10DV*	10	n.a./27	1 x 4 kW + 2 x 3 kW	No	Yes
12PHRX12DV*	12	n.a./32	3 x 4kW	No	Yes

Models marked \* are not suitable for spa use. For 10 and 12 kW heaters, use models 12PHR10DV/SPA and 12PHR12DV/SPA respectively.

## Weights and dimensions

Packed dimensions:

425 x 450 x 190mm

Packed weight:

26 kg

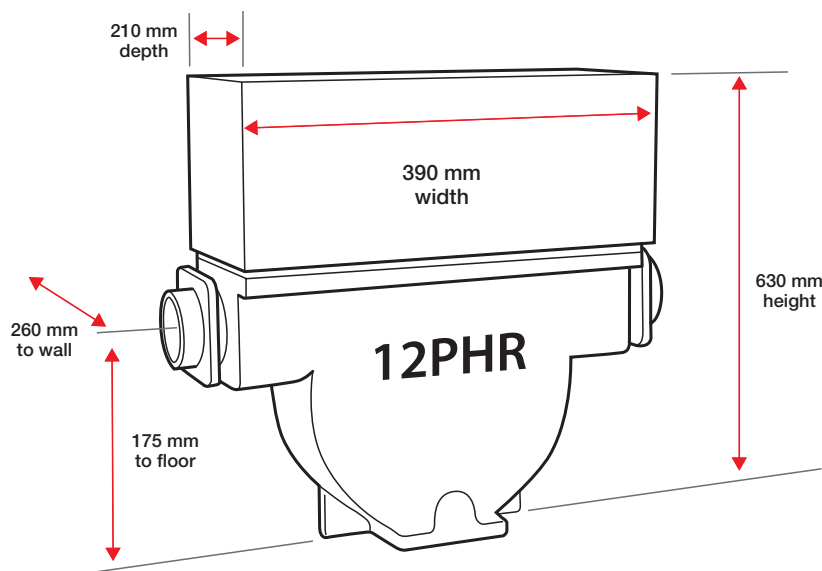

## Thermalec Pool & Spa Products

Kingsley Close, East Way, Lee Mill Industrial Estate  
 Ivybridge, Devon PL21 9LL United Kingdom  
 Telephone +44 (0) 1752 313343  
 Fax +44 (0) 1752 313353  
 E-mail [info@thermalec.co.uk](mailto:info@thermalec.co.uk)  
 Web [www.thermalec.co.uk](http://www.thermalec.co.uk)

